



SWV Series Oil-Free Screw Compressor

SWV15 - 37





SWV-series

Air compressors provide clean, good quality oil-free compressed air with injected water into compression process.

High efficiency

The injected water of SWV-series is the functions of sealant and coolant.

Sealant : Injected water can reduce leakage between rotors and housing, which improved the compressor efficiency by 15% as compared to dry screw compressor.

Cooling : Injected water is mixed with compressed air and efficiently cool down and dissipate heat generated in compression process. The compression is near to isothermal compression.

High reliability

The start of the art design on airends of SWV series provide good air quality, perfect performance and high reliability. Oil free air is the trend of global world compressor market. Environment friendly, availability are important issues to customers.

Low maintenances intervals

Professional engineering design and precise machining with long bearing life. The maintenance interval is enlarged.

Oil-free Air Compressor application industries:



Fu Sheng products
Quick and good
service



"All-in-one": simple
installation, high
quality and low
total cost
investment



Medical Air Supply
100% Oil-free
clean air



Small number of
component parts
and consumable
material
Low maintenance
cost



Instrument Air
Highly Efficient
Air Supply

- Drying
- Agitation
- Air blowing
- Painting dressing
- Chemical analysis
- Instrument control
- Bacteria cultivation
- Petrochemical industry
- Steel and Hi-tech industries
- Food and Chemical industries
- Powdered substance conveyance
- Papermaking and Textile industries
- Electronics and Appliance industries
- Pharmaceutical and Medical industries

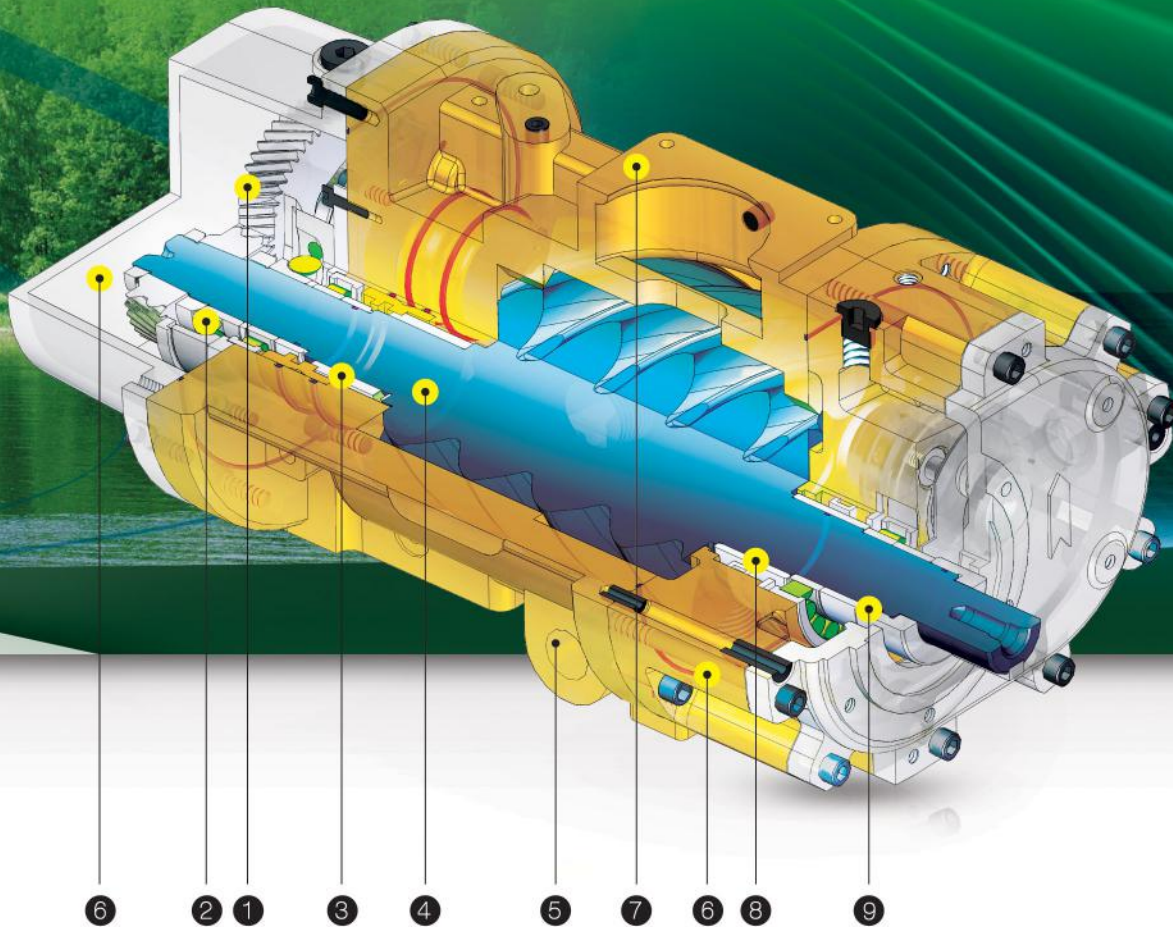

- | | | |
|-------------------|-----------------------------|--------------------|
| ① Timing gear | ④ Male/female rotor | ⑦ Suction position |
| ② Bearing | ⑤ Main water injection port | ⑧ Seal(suction) |
| ③ Seal(discharge) | ⑥ Oil box | ⑨ Seal(shaft) |

Advantages of SWV air-end

- Direct coupling driven, low power loss
- 100%, oil-free compressed air, ensure clean air and safety.
- Splashing oil lubrication on bearings, better than grease lubrication.
- Variable speed drive technology, ensure stable system pressure and energy saving.

Dry air

Low viscosity injected water is easily separated from compressed air. The separated compressed air is in 100% RH and can be easily dried by dryer.

Low noise

With injected water, the airend can be run in much lower speed compare to dry screw compressor with lower noise. The new design enclosure ensure the compressor is operated in low noise.

Reliable sealing system

The airends of SWV series are supported by precise roller bearings with oil lubrication. The compression chamber and bearing chamber is separated by a buffer chamber with oil seal and water seal. The leakage from oil side into compression chamber is avoided.

Environmental protection

Alloys and special surface treatment are applied to prevent any corrosion on the airend and components. Injected water is filtered by high quality water filter to ensure clean, good quality water.

Isothermal compression

Heat generated in compression process is taken by injecting water into compression chamber. Water film seals the gaps between rotors and housing to reduce internal leakage. The compression is nearly isothermal compression in optimum efficiency. For theoretically adiabatic compression, inlet air at 20°C can be compressed at 7 bar(g) with over 250°C temperature. With injected water as coolant, the temperature of compression chamber can be cool down to 40°C in high efficiency and isothermal.

SWV 22/37 System Flow Chart

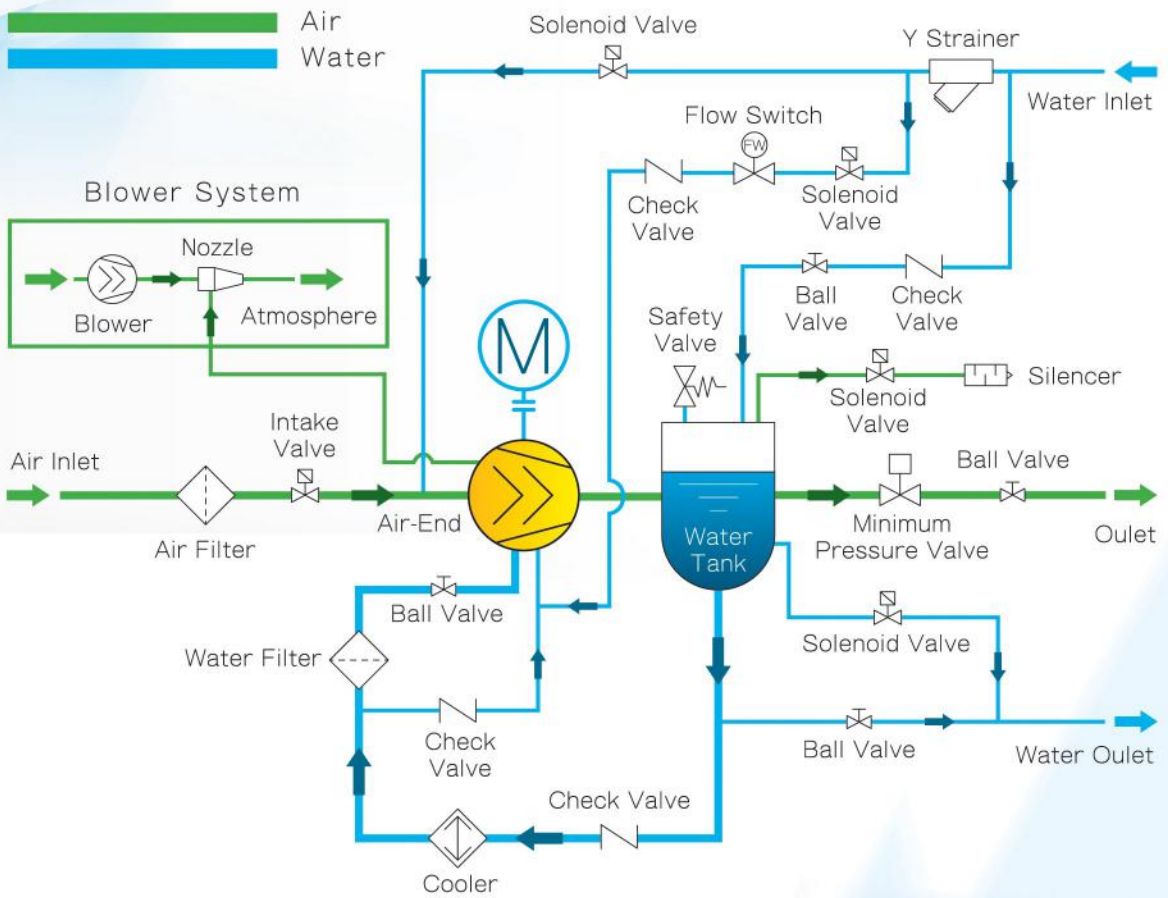

SWV15/37 Specification table

Type cooling method	Unit	SWV15A	SWV22A	SWV30A	SWV37A	SWV37W
F.A.D. (m ³ /min) (ISO 1217 / Annex C)	7 bar(g)	2.2	3.4	4.7	5.8	5.8
	8 bar(g)	2.1	3.1	4.4	5.3	5.3
	9 bar(g)	2.0	3.0	4.3	5.0	5.0
Horsepower	kW (HP)	15(20)	22(30)	22(30)	37(50)	37(50)
Voltage	V	220 / 380 / 440				
Pressure control method	-	Inverter constant pressure control				
Intake pressure & temp.	-	2~40°C at atmospheric pressure				
Drive method	-	Direct coupling				
Discharge temperature	°C	Air cooling: < ambient temp. +24°C				Water cooling: < cooling water temp. +14°C
Cooling water flow(32°C)	L/min	-				125
Outline dimension	mm	1900	1900	2100	2100	2100
	mm	1100	1100	1200	1200	1200
	mm	1750	1750	1850	1850	1850
Weight	kg	1000	1000	1400	1400	1400
Air outlet	inch	1	1	1 1/2	1 1/2	1 1/2

SWV Series Oil-Free Screw Compressor

Clean, good quality injected water with precise water filter, to filter impurities in the air.



SWV-series features

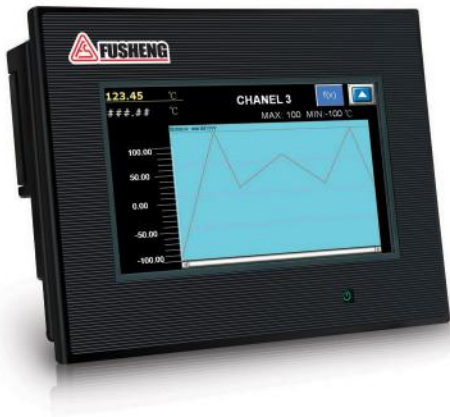

Fusheng inverter control unit

- Microprocessor intelligent control.
- Complete protection functions capability.
- Color touch screen, easy and convenient operating.
- Working pressure is constantly sustained within ± 0.1 bar.

Except power saving VSD compressor unit also ensures:

- Reduced starting current.
- Stable, constantly compressed air.
- Extended compressor unit service life.
- Electrical motor power factor improved.
- Elimination of high star delta start current.

Linear operating and output

- Power saving up to 35% as compared to traditional modulation control compressors.
- Linear inverter control output can be achieved, depending on the demanded of load. (20~100%)

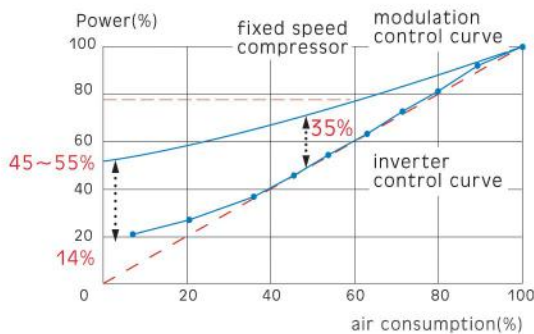

Stable pressure compressed air system

- Fast response to air demand change keeps working pressure constant within ± 0.1 bar.
- Saving up to 8% energy that is additionally required in traditional load/unload control compressor units due to pressure difference setting of 1 bar.

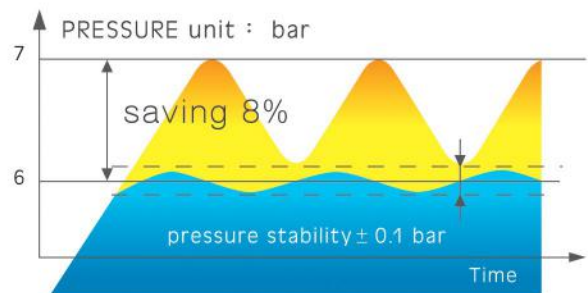

VSD compressor unit saving benefits

VSD compressor unit operating service life period can ensure operational cost savings as high as 35% .

- Maintenance 9%
- Installation 2%
- Purchasing cost 12%
- Energy consumption 42%
- Saving 35% (end user benefit)

VSD compressor unit



Standard compressor unit

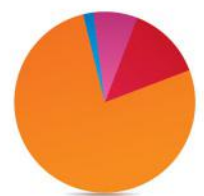



SWV Series Oil-Free Screw Compressor
SWV15 - 37

FUSHENG INDUSTRIAL CO., LTD

HEAD OFFICE

No. 172, Sec.2, Nanjing E. Rd., Zhongshan Dist.,
Taipei City 104, Taiwan (R.O.C)
TEL : (+886) 2-2507-2211 FAX : (+886) 2-2504-7870

FACTORY (SALES OFFICE)

No. 60, Sec. 2, Guangfu Rd., Sanchong Dist., Taipei City 241,
Taiwan (R.O.C)
TEL : (+886) 2-2995-1411 FAX : (+886) 2-2995-7925
Mail : machinery.sc@fusheng.com
Website: <http://www.fusheng.com>

FUSHENG (VIETNAM)

No. 06, 3A Road, Bien Hoa Industrial Zone II, Dong Nai, Vietnam
TEL:(+84) 251-383-4566 FAX:(+84) 251-383-4599
E-Mail : sales@fusheng.com.vn
Mail : sales@fusheng.com.vn
Website: <http://www.vn.fusheng.com>

FUSHENG (THAILAND)

140/1-2 Moo.12 Soi.9/1 Kingkaew Rd., T.Rachathewa,
A.Bangplee, Samutprakarn 10540, Thailand
TEL:(+66) 2-312-4547 FAX:(+66) 2-312-4530
Mail : sales.fsth@fusheng.com
Website: <http://www.th.fusheng.com>

FUSHENG (MALAYSIA)

No.08 , Jalan Para U8/103 , Metropolitan Business Park ,
Seksyen U8 , Bukit Jelutong , 40150 Shah Alam , Selangor
Darul Ehsan, Malaysia
TEL :(+60) 3-7832-3952 FAX :(+60) 3-7832-1954
Mail : fsmy_sales@fusheng.com
Website: <http://www.my.fusheng.com>

FUSHENG (INDONESIA)

Taman Tekno Blok H-9 / 23 - 25 , Bumi Serpong Damai
Sector XI , Tangerang 15314 , Indonesia
TEL:(+62) 21-2275-6671 FAX:(+62) 21-2275-6672
Mail : info.indonesia@fusheng.com
Website: <http://www.id.fusheng.com>



Distributor/Sales Representative

SWV-10705-112A000-E2